



# Hydraulic Pressure Switch Instruction Manual

**MODEL: CVS1**

SFA Companies 10939 N. Pomona Ave. Kansas City, MO 64153  
Tel: 888-332-6419 \* Fax: 816-891-6599  
E-mail: sales@bvahydraulics.com Website: www.bvahydraulics.com

## Maximum Operating Pressure 10,000 PSI

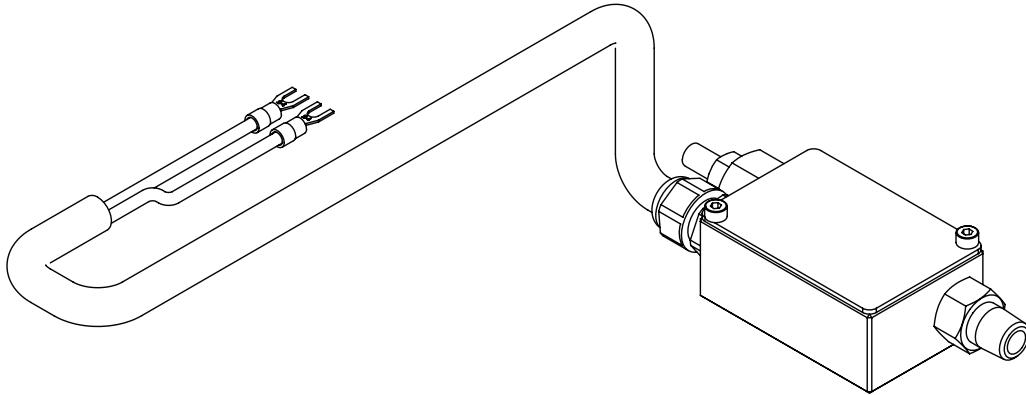

*This is the safety alert symbol. It is used to alert you to potential personal injury hazards. Obey all safety messages that follow this symbol to avoid possible injury or death.*

## SAFETY AND GENERAL INFORMATION

**Save these instructions.** For your safety, read and understand the information contained within. The owner and operator shall have an understanding of this product and safe operating procedures before attempting to use this product. Instructions and safety information shall be conveyed in the operator's native language before use of this product is authorized. Make certain that the operator thoroughly understands the inherent dangers associated with the use and misuse of the product. If any doubt exists as to the safe and proper use of this product as outlined in this factory authorized manual, remove from service immediately.

**Inspect before each use.** Do not use if leaking, broken, bent, cracked or otherwise damaged parts are noted. If the valve has been or suspected to have been damaged, discontinue use until checked out by a BVA Hydraulics authorized service center. Owners and operators of this equipment shall be aware that the use and subsequent repair of this equipment may require special training and knowledge. It is recommended that an annual inspection be done by qualified personnel and that any missing or damaged parts, decals, warning/safety labels or signs be replaced with BVA Hydraulics authorized replacement parts only. Any relief valve that appears to be damaged in any way, is worn or operates abnormally shall be removed from service immediately until such time as repairs can be made.

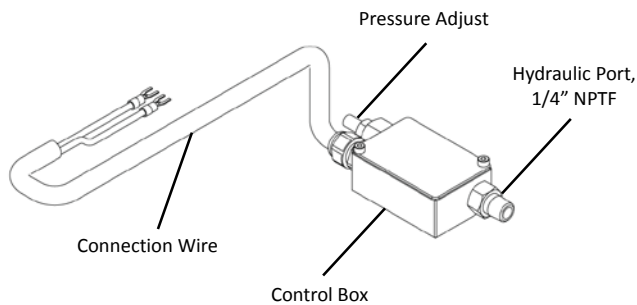

Figure 1: Typical CVS1 Components

## PRODUCT DESCRIPTION

BVA Hydraulics Pressure Switch limits pressure developed by the hydraulic pump, regulating the force imposed on other components. A wide variety of applications exist for this category of product. Special skill, knowledge and training may be required for a specific task and the product may not be suitable for all the jobs described above. The user ultimately must make the decision regarding suitability of the product for any given task and therefore accept responsibility for that decision.

- ⚠ WARNING:** Always wear proper personal protective gear when operating hydraulic equipment (i.e. safety glasses, gloves, etc.)
- ⚠ CAUTION:** Always check connections before using. Alteration of these products is strictly prohibited. Use only those equipment and attachments provided and approved by the manufacturer.
- ⚠ WARNING:** To reduce the risk of personal injury and/or property damage, ensure that the rated working pressure of each pressurized attachment be equal to or greater than the rated working pressure developed by the hydraulic pump.

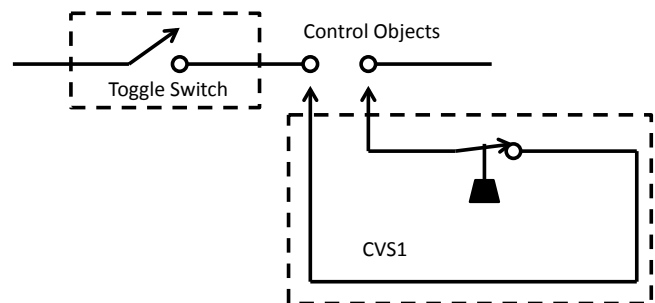

Figure 2: Wiring Diagram for BVA CVS1

## SPECIFICATIONS

Model No.	Operating Pressure (PSI)	Max. Amperage (A)	Max. Working Voltage (V)	Hydraulic Port	Length of Connection Wire (In.)	Dimension (In.)	Weight (Lbs.)	Pressure Switch Adjustability (PSI)	Pressure Switch Adjustability (psi)
CVS1	10,000	15	250	1/4" NPTF	19.5	5.6 x 2.0 x 1.4	1.3	1,000 ~ 10,150	1,000 - 10,150

# ⚠ WARNING



**Failure** to comply with the following warnings may result in **personal injury** as well as **property damage**.



- Study, understand, and follow all instructions provided with and on this device before use.
- The user must be a qualified operator familiar with the correct operation, maintenance, and use of cylinders.



Wear protective gear when operating hydraulic equipment.



This device is **NOT** suitable for use as **support** device! As the load is lifted, use blocking and cribbing to guard against a falling load. Stay clear of a lifted load before it is properly supported. Never rely on hydraulic pressure to support a load.



**Crush Hazard.** Keep hands and feet away from cylinder and workpiece during operation.



- Do not exceed rated capacity of any equipment in the system. The relief valve is designed for a max. pressure of 10,000 psi.
- Do not connect to a pump with higher pressure rating.
- Do not subject the system shock loads (a load dropped suddenly causing the system pressure to exceed rated pressure).



The system operating pressure must not exceed the pressure rating of the lowest rated component the system. Install a pressure gauge or other load measuring instrument to monitor the operating pressure. Burst hazard exists if hose, connection or any other component in the system exceed its rated pressure.



Avoid damaging hydraulic hose. Do not allow hose to kink, twist, curl, crush, cut or bend so tightly that fluid flow within the hose is blocked or reduced. Periodically inspect the hose for wear.



Do not pull, position or move system by hydraulic hose. Use carrying handle or other means of safe transport.



Do not handle pressurized hoses. Never attempt to grasp a leaking pressurized hose. Ensure to release the system pressure before disconnecting hydraulic hose or connections.



Hydraulic fluid can ignite and burn. Keep hydraulic equipment away from flames and heat. Excessive heat will soften seals, resulting in fluid leaks. Heat also weakens hose materials.



System must be on a stable base which is able to support the load while pushing or lifting. Use shims, friction material or constrains to prevent slippage of the base or load. Ensure cylinder is fully engaged into/onto adapters, extension accessories.

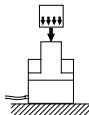

Center load on cylinder. Distribute load evenly across the entire saddle surface. Do not off-center loads on a cylinder. The load can tip or the cylinder can “kick out”.



Never try to disassemble relief valve, refer repairs to qualified, authorized personal. Contact BVA Hydraulics tech service for authorized service center.



Do not subject hose to sharp objects or heavy impact.



Hose material or seals must not come in contact with corrosive materials such as battery acid, creosote-impregnated objects and wet paint. Never paint a coupler or hose.



- No alteration shall be made to the valve.
- Use only factory authorized fasteners, accessories and hydraulic fluid.

## INSTALLATION AND ADJUSTMENT

### PUMP MOUNTED INSTALLATION

Mount the pressure switch to the control valve or the manifold by threading the switch fitting into the port provided for a pressure gauge. An elbow may be used to change the angle, and a tee fitting can be used if both a pressure switch and gauge are required.

### PRESSURE REGULATING CONTROL ADJUSTMENTS

The pressure regulating valve can be adjusted to bypass oil at a specific pressure setting so that the pump will continue to run. The pressure switch can be adjusted to stop the pump motor at a specific pressure setting and then restart the pump when the pressure falls below that setting.

### ADJUSTING THE PRESSURE REGULATING VALVE

Adjust the pressure regulating valve by increasing to a preferred pressure setting. Do not adjust by decreasing from a higher to a lower pressure.

1. Place pipe plugs in valve ports.
2. Loosen the locknut on the pressure regulating valve. Turn the adjusting screw a few turns counterclockwise to decrease the pressure setting to a lower than desired pressure.
3. Connect the pump power supply and place the hydraulic control valve in the ADVANCE position. Set the motor control toggle switch to RUN.
4. Slowly turn the adjusting screw in the clockwise direction. this will gradually increase the pressure setting. When the preferred setting is reached, lock the adjusting screw in position by tightening the locknut.

### ADJUSTING THE PRESSURE SWITCH

The pressure switch is generally used and adjusted with the pressure regulating valve. A pressure switch can also be used alone for activating electrical devices such as motors, solenoids, relays, etc. which are located elsewhere in the circuit.

1. Loosen the locknut on the pressure switch. Turn the adjusting screw in the clockwise direction to increase the pressure setting and counterclockwise to decrease pressure.
2. Connect the pump power supply and place the control valve in the ADVANCE position. Set the motor control toggle switch on RUN.
3. Slowly turn the pressure switch adjusting screw in counterclockwise direction, decreasing the pressure setting until the pump motor shuts off. Then tighten the locknut to lock the adjusting screw.
4. Move the hydraulic flow control valve to the RELEASE position to relieve the hydraulic pressure. Move the control valve back to ADVANCE and start the hydraulic pump again to check the pressure setting. It may be necessary to make a second fine adjustment.

### ADJUSTING THE PRESSURE SWITCH ELECTRICAL SWITCH



**WARNING:** *Disconnect the power supply before removing the electrical box cover*

1. Remove the top cover of the switch. Loosen the two set screws located inside the switch body.
2. Place a .020 thick shim between the spring retainer and the dowel pin. Loosen the spring retainer set screw and tighten the spring retainer until it contacts the shim. Lock the spring retainer in place by tightening the set screw.
3. Slide the switch bracket towards the shim until the switch button contacts the shim surface. Secure the switch mounting bracket by tightening the set screw located inside the bottom cover.
4. Connect a multimeter to the electrical cord. Tighten the switch adjustment screw against the switch mounting bracket until the switch button contacts the platen and actuates. The multimeter will react when the button actuates and an audible click can be heard. Continue tightening the switch adjustment screw 1/8 turn after the switch button actuates.
5. Put the top cover back on the switch.



# Hydraulic Pressure Switch Service Parts

## MODELS: CVS1

SFA Companies 10939 N. Pomona Ave. Kansas City, MO 64153  
 Tel: 888-332-6419 \* Fax: 816-891-6599  
 E-mail: sales@bvahydraulics.com Website: www.bvahydraulics.com

**Note:** Not all components of the cylinder are replacement items, but are illustrated as a convenient reference of location and position in the assembly sequence. To ensure safe and reliable performance, replace worn or damaged parts with BVA authorized repair parts only.

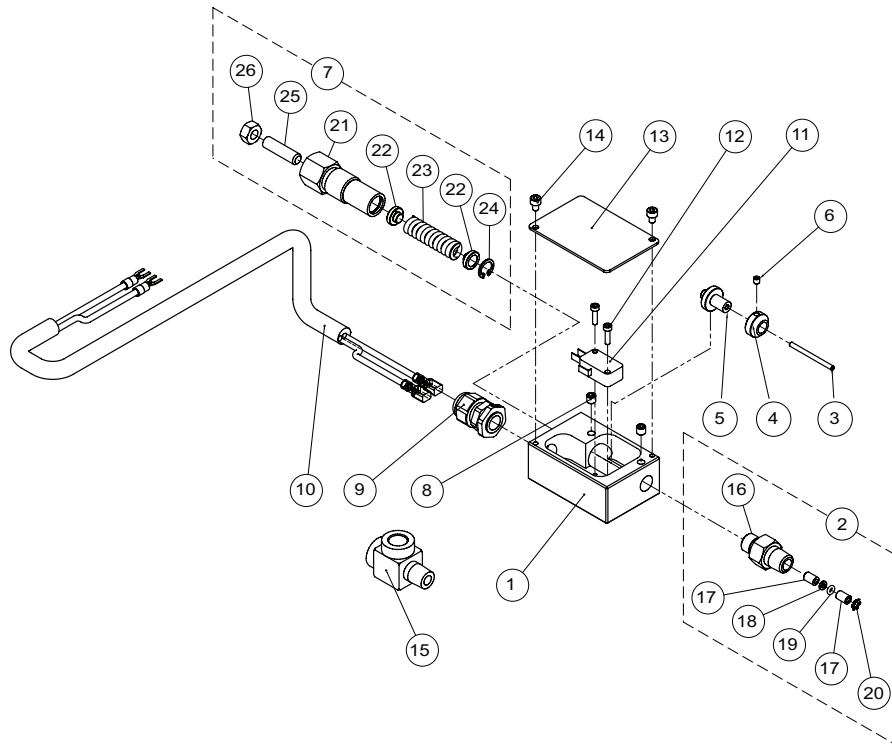

Item	Part No.	Description	Qty.
1	N/A	Switch Body	1
2	D09-4-2030-104	Cartridge Assembly	1
3	D09-6-2033-102	Dowel Pin	1
4	D09-6-2034-104	Switch Bracket	1
5	D09-6-2035-106	Alex Bushing	1
6	644-1-0040-204	Set Screw	1
7	D09-4-2031-106	Spring Retainer Assy.	1
8	644-1-0060-05311	Set Screw	2
9	E05-6-9208-107	Nylon Cable Gland	1
10	E06-6-9209-109	Connection Wire	1
11	E05-6-9300-105	Limit Switch	1
12	649-1-0030-123	Hex Bolt	1
13	D09-6-2038-102	Cover Plate	1
14	649-1-0040-007	Hex Bolt	2

Item	Part No.	Description	Qty.
15	D01-6-1028-108	Tee Connector	1
16	N/A	Cartridge	1
17	N/A	Bushing	2
18	*	Back-Up Washer	1
19	*	O-Ring	1
20	*	Circular Internal	1
21	N/A	Spring Retainer	1
22	D09-6-2037-100	Spring Disc	2
23	512-2-0125-100	Compression Spring	1
24	666-5-0130-108	Retaining Ring "C"	1
25	641-1-0080-104	Adjusting Screw	1
26	651-2-0080-034	Nut	1
*	D09-3-9930-109	Repair Kit	

## LIMITED LIFETIME WARRANTY

BVA Hydraulics®, represented in the United States by SFA Companies ["SFA"] warrants this product to be free from defects in material and workmanship for the life of the product as long as the original purchaser owns the product. The warranty is non-transferable and is subject to the terms, exclusions, and limitations described below:

- Damaged components, including but not limited to bent rams, dented or crushed cylinder walls, broken welds or couplers as well as worn out seals, o-rings and springs are the result of misuse and not covered by warranty and BVA Hydraulics will not provide any warranty credit for such damaged components.
- This warranty does not cover ordinary wear and tear, overloading, alterations (including repairs or attempted repairs not performed by BVA Hydraulics or one of its authorized personnel), improper fluid use, or use of the product in any manner for which the product was not intended or the use of which is not in accordance with the instructions or warnings provided with the product.
- In the unlikely event that a BVA Hydraulics product fails due to material defect in workmanship, you may contact SFA for disposition. In such cases, the customer's sole and exclusive remedy for any breach or alleged breach of warranty is limited to the repair or replacement of the defective product.
- Under no circumstances is BVA Hydraulics liable for any consequential or incidental damage or loss whatsoever.
- THIS WARRANTY IS LIMITED TO NEW PRODUCTS SOLD THROUGH AUTHORIZED DISTRIBUTORS AND OTHER CHANNELS DESIGNATED BY BVA HYDRAULICS. NO AGENT, EMPLOYEE OR OTHER REPRESENTATIVE OF BVA HYDRAULICS IS AUTHORIZED TO MODIFY THIS WARRANTY.
- THE FOREGOING IS EXCLUSIVE AND IS IN LIEU OF ALL OTHER EXPRESS AND IMPLIED WARRANTIES, INCLUDING BUT NOT LIMITED TO THE IMPLIED WARRANTIES OF MERCHANTABILITY AND FOR A FITNESS FOR A PARTICULAR PURPOSE.
- Components not manufactured by BVA Hydraulics including certain motor systems, gasoline engines, and other are not covered by this warranty and instead are covered by the manufacturer's separate manufacturer's warranty provided in the package.
- BVA Hydraulics' liability in all cases is limited to, and will not exceed the purchase price paid for the product.

---

SFA Companies  
10939 N. Pomona Ave. Kansas City, MO 64153  
Tel: 888-332-6419  
E-mail: [sales@bvahydraulics.com](mailto:sales@bvahydraulics.com)





