



Maintenance Kit Instruction Manual

MODELS NUMBERS: J50200

SFA Companies 10939 N. Pomona Ave. Kansas City, MO 64153
 Tel: 888-332-6419 * Fax: 816-448-2142
 E-mail: sales@bvahydraulics.com Website: www.bvahydraulics.com



This is the safety alert symbol. It is used to alert you to potential personal injury hazards. Obey all safety messages that follow this symbol to avoid possible injury or death.

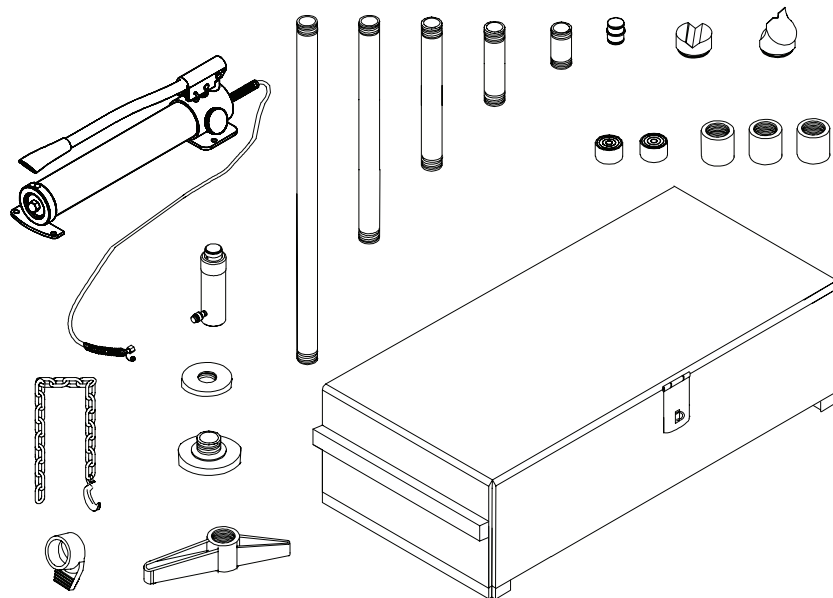

⚠️ ADVERTENCIA

- Leer, comprender, y seguir las instrucciones antes de utilizar el aparato.
- El manual de instrucciones y la información de seguridad deben estar comunicados en lengua del operador antes del uso.
- No seguir estas indicaciones puede causar daños personales o materiales.

⚠️ WARNING

To avoid **crushing and related injuries**:



- **NEVER** allow personnel to work or pass under a load until the load is secured by cribbing, blocking, or other mechanical means.

Read this manual and follow all the Safety Rules and Operating Instructions before using this product.

Save these instructions. For your safety, read and understand the information contained within. The owner and operator shall have an understanding of this product and safe operating procedures before attempting to use this product. Make certain that the operator thoroughly understands the inherent dangers associated with the use and misuse of the product. If any doubt exists as to the safe and proper use of this product as outlined in this factory authorized manual, remove from service immediately.

Inspect before each use. Do not use if broken, bent, cracked or otherwise damaged parts are noted. If any component of this product has been or suspected to have been subjected to a shock load (a load dropped suddenly, unexpectedly upon it), discontinue use until checked out by a BVA Hydraulics authorized service center. Owners and operators of this equipment shall be aware that the use and subsequent repair of this equipment may require special training and knowledge. It is recommended that an annual inspection be done by qualified personnel and that any missing or damaged parts, decals, warning / safety labels or signs be replaced with factory authorized replacement parts only. Any component of this Maintenance Kit that appears to be damaged in any way, is worn or operates abnormally shall be removed from service immediately until such time as it can be repaired/replaced. Labels and Instruction Manuals are available from manufacturer.

PRODUCT DESCRIPTION

BVA Hydraulics Maintenance Kits are designed to be used for pushing, spreading, and pressing of vehicle body panels as well as various component parts and assemblies. A variety of attachments are included.

! *To reduce the risk of personal injury and/or property damage, ensure that the rated working pressure of each pressurized attachment be equal to or greater than the rated working pressure developed by the hydraulic pump.*

! *Always check connections before using. Alteration of these products is strictly prohibited. Use only those adapters and attachments provided and approved by the manufacturer.*

! *When extension tubes and/or offset attachments are used, the rated capacity **must be** reduced by 50% for each tube or offset attachment connected. See Parts Section for identification of "offset" attachments.*

BEFORE USE (see Fig. 1, 3, 4)

1. Before using this product, read the owner's manual completely and familiarize yourself thoroughly with the product, its components and recognize the hazards associated with its use.
2. Inspect before each use. Do not use if bent, broken, leaking or damaged components are noted.
3. Check to ensure that all parts of your kit are included (see illustration and parts list).
4. Locate and open release valve, counter-clockwise, 1/2 turn. Pull spring loaded lock pin, pivot toward rear to unlock pump handle.
5. Loosen the vent screw by turning it counter-clockwise to purge air out from the hand pump.

BEFORE USE (continued)

6. Carefully remove the dust caps and plugs from hose coupler and ram coupler.
7. Connect hose coupler to ram coupler, ensure that there are no fluid leaks.
8. Close release valve by turning it clockwise, by hand, until firm resistance is felt to further thread engagement. Pump handle until ram fully extends, then open the release valve (counter-clockwise) until ram has fully retracted.

NOTE: DO NOT turn release valve more than **1** full counter-clockwise rotation. If the ram has not fully retracted, contact BVA technical service at (888)332-6419.

GENERAL SAFETY INFORMATION

1. Ensure that attachments are fully engaged before applying load.
2. Ensure that load is centrally applied to attachment or ram saddle. Do not load off center.
3. Always monitor the force applied to workpiece by using a load cell and indicator or you may monitor pressure developed in the ram by using an inline pressure gauge, then calculate the applied force using the formula:
 $F = P \times A$, where F = lbs force, P = pressure in psi, and A = effective ram area in in².

Ram Area of Model J50200 is: 5.14in²

Refer to Load-Pressure correlation chart on page 10. If bowing or bending of ram or any attachment occurs during use, **"STOP"**, release pressure immediately and reconsider application. Application may not be compatible with product, a ram kit with a higher capacity may be needed.

Pump and Ram Component Nomenclature	
A- Operating handle	E- Ram coupler
B- Handle lock-pin	F- Hose
C- Release valve	H- Oil filler/vent screw
D- Ram cylinder	

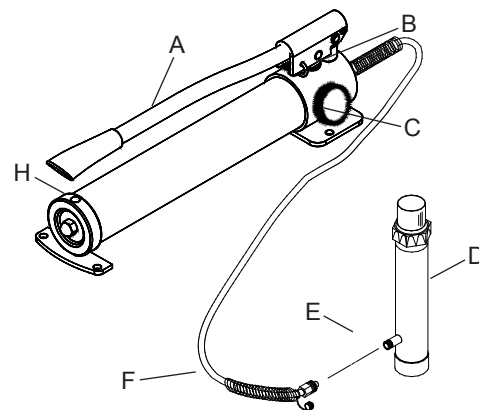

Figure 1 - Pump and Ram Components

SPECIFICATIONS

Model J50200 Maintenance Kit									
Kit Component	Operating Pressure (psi)	Rated Capacity (tons)	Closed Height (in)	Extended Height (in)	Effective area (in ²)	Oil Capacity (in ³)	Weight (lbs)	Oil Displacement per Stroke (in ³)	
								1st Stage	2nd Stage
HT2005 Ram	7750	20	11.77	16.93	5.14	26.52	21	-	-
P1000 Pump	10,000	-	-	-	-	61	13	0.81	0.14

WARNING



- Study, understand, and follow all instructions provided with and on this device before use.
- The user must be a qualified operator familiar with the correct operation, maintenance, and use of rams.



Wear protective gear when operating hydraulic equipment.



This device is **NOT** suitable for use as **support** device! As the load is lifted, use blocking and cribbing to guard against a falling load. Stay clear of a lifted load before it is properly supported. Never rely on hydraulic pressure to support a load.



Crush Hazard. Keep hands and feet away from ram and workpiece during operation.



- Do not exceed rated capacity of the ram or any equipment in the system. The ram is designed for a max. pressure of 10,000 psi.
- Do not connect a ram to a pump with higher pressure rating.
- Do not subject ram to a shock loads, a load dropped suddenly, causing the system pressure to exceed rated pressure.



The system operating pressure must not exceed the pressure rating of the lowest rated component the system. Install a pressure gauge or other load measuring instrument to monitor the operating pressure. Burst hazard exists if hose, connection or any other component in the system exceed its rated pressure.



Avoid damaging hydraulic hose. Do not allow hose to kink, twist, curl, crush, cut or bend so tightly that fluid flow within the hose is blocked or reduced. Periodically inspect the hose for wear.



Do not pull, position or move ram setup by the hose. Use carrying handle or other means of safe transport.



Do not handle pressurized hoses. Never attempt to grasp a leaking pressurized hose. Ensure to release the system pressure before disconnecting hydraulic hose or connections.



Hydraulic fluid can ignite and burn. Keep hydraulic equipment away from flames and heat. Excessive heat will soften seals, resulting in fluid leaks. Heat also weakens hose materials.



Ram must be on a stable base which is able to support the load while pushing or lifting. Use shims, friction material or constrains to prevent slippage of the base or load. Ensure ram is fully engaged into/onto adapters, extension accessories.

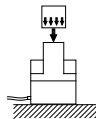

Center load on ram. Distribute load evenly across the entire saddle surface. Do not off-center loads on a ram. The load can tip or the ram can “kick out”.



Never try to disassemble a hydraulic ram, refer repairs to qualified, authorized personal. Contact BVA Hydraulics tech service for authorized service center.



Do not subject hose to sharp objects or heavy impact.



Hose material or seals must not come in contact with corrosive materials such as battery acid, creosote-impregnated objects and wet paint. Never paint a coupler or hose.



- No alteration shall be made to the ram.
- Use only factory authorized fasteners, accessories and hydraulic fluid.



Failure to heed the messages, markings, and instructions provided with and on this device may result in personal injury and/or property damage.

OPERATION (refer to Figures 1~4)

! ***ALWAYS** monitor pressure, load or position using suitable equipment. Pressure may be monitored by means of an optional manifold and gauge. Load may be monitored by means of a load cell and digital indicator.*

Note: Any attachment that is not loaded centrally, as through the centerline of the ram, is considered to be "offset". When extension tubes and/or offset attachments are used, the rated capacity must be reduced by 50% for each tube and/or offset attachment connected (see Page 5 for setup examples).

1. Pump may be used in horizontal and vertical position as illustrated in figure 2 below.

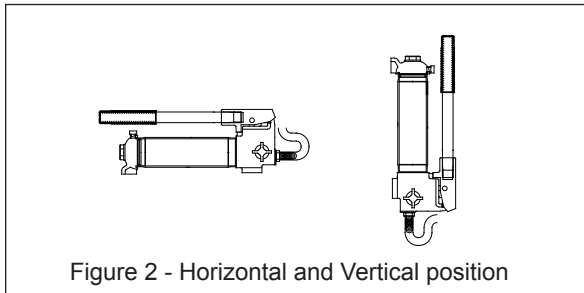

Figure 2 - Horizontal and Vertical position

2. Locate and close release valve by turning it clockwise until firmly closed. (Do not over tighten)
3. Operate by pumping handle. This will send fluid from the pump reservoir into the high pressure hose assembly and into the ram assembly.
4. Continue pumping until ram reaches desired position.

! ***NEVER** operate pump with release valve closed and disconnected from application. If operated in this condition, the hose and connections become pressurized. This increases burst hazard.*

5. To Release Pressure on work piece: Slowly, carefully turn the release valve counter-clockwise until ram retracts to desired position. Never turn release valve more than 1 full turn. The ram return system is spring loaded and the release valve system is metered, allowing controlled retraction of the ram.

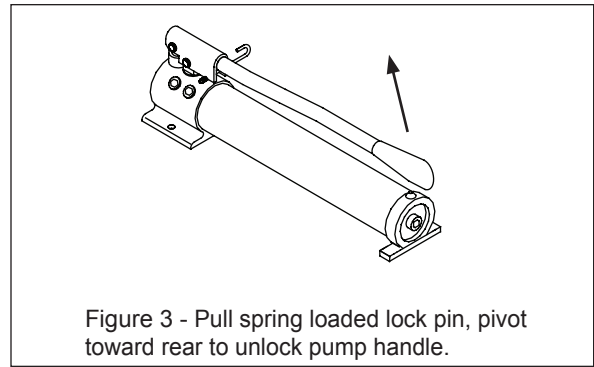

Figure 3 - Pull spring loaded lock pin, pivot toward rear to unlock pump handle.

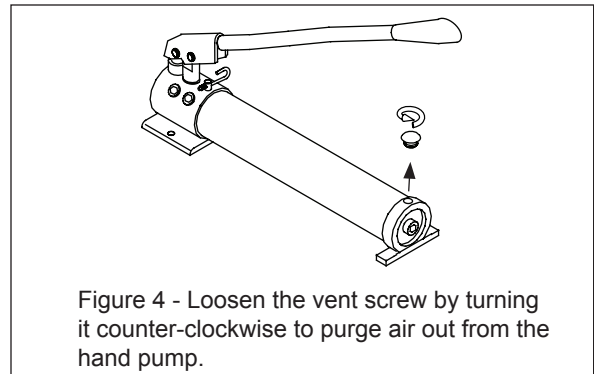
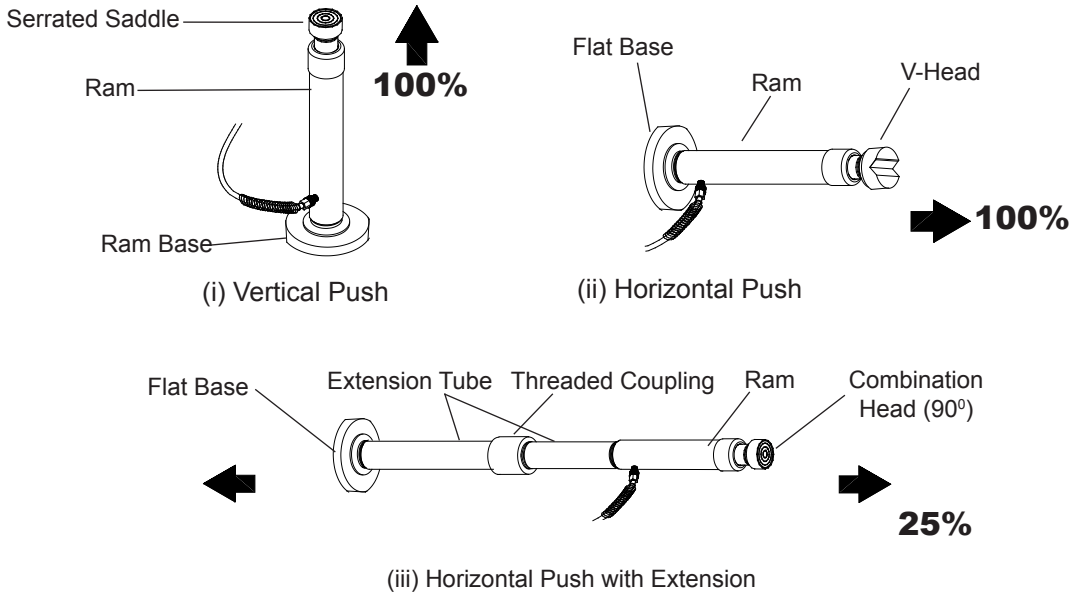

Figure 4 - Loosen the vent screw by turning it counter-clockwise to purge air out from the hand pump.

Basic Setup

The capacity of the maintenance kit can be significantly affected by the number of attachments used and the type of load applied. The approximate load capacity of each function setup is illustrated below. When two or more extension tubes are used together, be sure to position the shortest tube further away from the ram.

A. Push



B. Pull

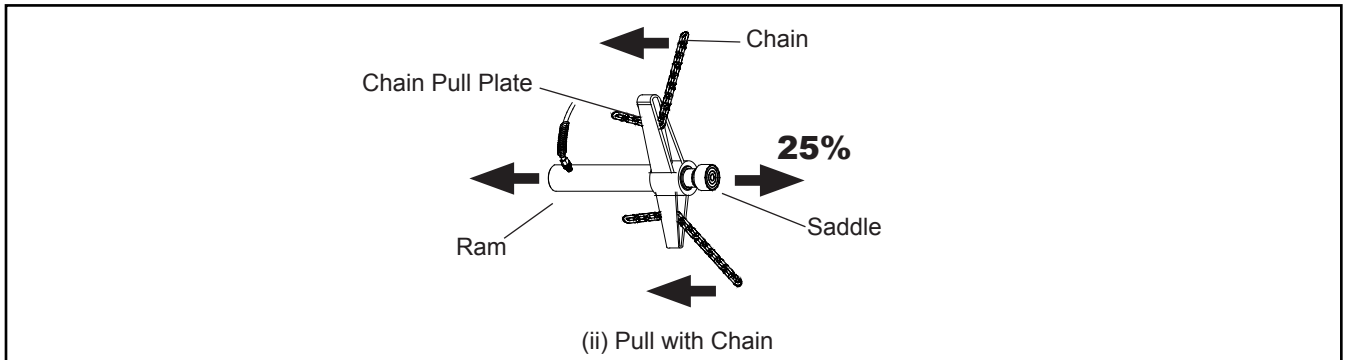

C. Spread

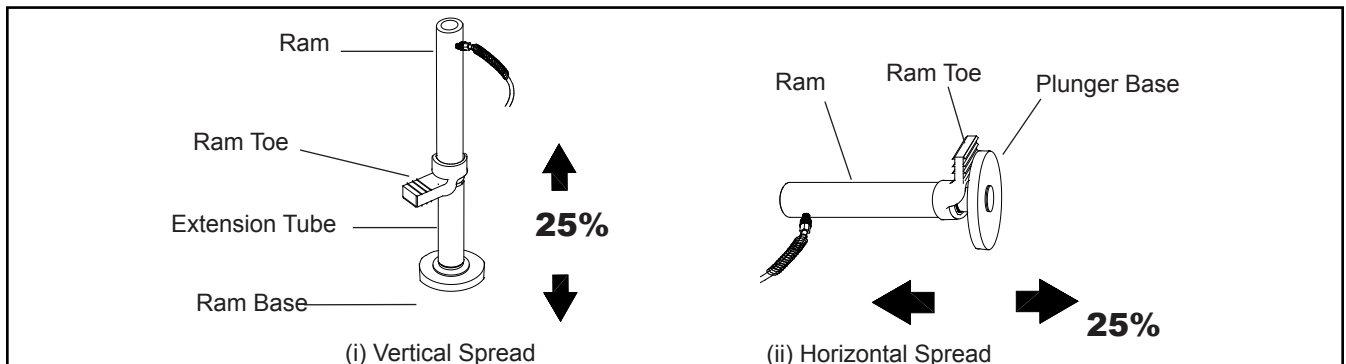

MAINTENANCE

1. Inspect hoses and connections daily. Replace damaged components immediately with Authorized BVA replacement parts only (see page 8).
2. Tighten connections as needed. Use pipe thread sealing compound when servicing hydraulic connections.
3. Use only a good grade hydraulic oil. DO NOT mix different types of fluid and NEVER use brake fluid, turbine oil, transmission fluid, motor oil or glycerin. Improper fluid can cause premature failure of the ram and the potential for sudden and immediate loss of load. We recommend BVA F01 or equivalent.

Adding oil

1. With ram fully lowered and release valve open, set pump unit in its normal, level position. Locate and remove oil filler / vent screw.
2. Fill until oil is within 3/8" of the oil filler screw hole opening, re-install oil filler / vent screw.

Changing oil

For best performance and increased system life, replace the complete fluid supply at least once per year.

1. With ram fully lowered, remove the oil filler / vent screw from the pump reservoir as above.
2. Lay the pump on its side and drain the fluid into a suitable container.

Note: Dispose of hydraulic fluid in accordance with local regulations.

3. Set pump in its level upright position.
4. Fill with good quality jack oil to within 3/8" of the oil filler / vent screw hole opening. Reinstall oil filler / vent screw.

ONE YEAR LIMITED WARRANTY

For a period of one (1) year from date of purchase, SFA Companies will repair or replace, at its option, without charge, any of its products which fails due to a defect in material or workmanship under normal usage. This limited warranty is a consumer's exclusive remedy.

Performance of any obligation under this warranty may be obtained by returning the warranted product, freight prepaid, to SFA Companies Warranty Service Department, 10939 N. Pomona Ave., Kansas City, MO 64153.

Except where such limitations and exclusions are specifically prohibited by applicable law.

- (1) THE CONSUMER'S SOLE AND EXCLUSIVE REMEDY SHALL BE THE REPAIR OR REPLACEMENT OF DEFECTIVE PRODUCTS AS DESCRIBED ABOVE.
- (2) SFA COMPANIES SHALL NOT BE LIABLE FOR ANY CONSEQUENTIAL OR INCIDENTAL DAMAGE OR LOSS WHATSOEVER.
- (3) ANY IMPLIED WARRANTIES, INCLUDING WITHOUT LIMITATION THE IMPLIED WARRANTIES OF MERCHANTABILITY AND FITNESS FOR A PARTICULAR PURPOSE, SHALL BE LIMITED TO ONE YEAR, OTHERWISE THE REPAIR, REPLACEMENT OR REFUND AS PROVIDED UNDER THIS EXPRESS LIMITED WARRANTY IS THE EXCLUSIVE REMEDY OF THE CONSUMER, AND IS PROVIDED IN LIEU OF ALL OTHER WARRANTIES, EXPRESS OR IMPLIED.
- (4) ANY MODIFICATION, ALTERATION, ABUSE, UNAUTHORIZED SERVICE OR ORNAMENTAL DESIGN VOIDS THIS WARRANTY AND IS NOT COVERED BY THIS WARRANTY.

Some states do not allow limitations on how long an implied warranty lasts, so the above limitation may not apply to you. Some states do not allow the exclusion or limitation of incidental or consequential damages, so the above limitation or exclusion may not apply to you. This warranty gives you specific legal rights, and you may also have other rights which vary from state to state.

Lubrication

A coating of light lubricating oil to pivot points and hinges will help to prevent rust and assure that pump assemblies move freely.

Cleaning

Periodically check the pump piston and ram for signs of rust or corrosion. Clean as needed and wipe with an oily cloth.



Paint contains lead!

DO NOT sand or grind painted surface!

Storage

When not in use, store with the pump piston and ram fully retracted.

How to remove faulty coupler:

If ram does not retract,:

1. Secure load by other means.
2. Depressurize pump and hose
3. Remove the ram from application.
4. Disconnect and replace with new coupler.

Important: Do not attempt to grasp ram with pliers or wrench without first wrapping the jaws of such tool with rags or similar padding.

TROUBLESHOOTING GUIDE

The following information is intended as an aid in determining if problem exists. Pump and ram should be repaired only by authorized BVA Service Center. For repair service, contact service center in your area.

Symptom	Possible Causes	Corrective Action
Erratic action	<ul style="list-style-type: none"> • Air in system or pump cavitation • External leakage in ram • Ram sticking or binding 	<ul style="list-style-type: none"> • Vent the system (refer to figure 3) • Contact service center • Contact service center
Ram will not extend, or respond to pressurized fluid	<ul style="list-style-type: none"> • Overload condition • Loose/Faulty couplers • Oil level in pump is low 	<ul style="list-style-type: none"> • Remedy overload condition • Tighten/Replace couplers • Fill and bleed the system
Ram extend only partially	<ul style="list-style-type: none"> • Oil level in pump is low • Overload condition • Ram is sticking or binding • Pump malfunction 	<ul style="list-style-type: none"> • Fill and bleed the system • Remedy overload condition • Contact service center • Contact service center
Ram move slower than normal	<ul style="list-style-type: none"> • Loose connection or coupler • Restricted hydraulic line or fitting • Pump not working correctly • Ram seals leaking 	<ul style="list-style-type: none"> • Tighten connection or coupler • Clean and replace if damaged • Check pump's operating instructions • Contact service center
Ram responds to pressurized fluid, but system does not maintain pressure	<ul style="list-style-type: none"> • Overload condition • Pump malfunctioning • Ram seals leaking 	<ul style="list-style-type: none"> • Remedy overload condition • Contact service center • Contact service center
Oil leaking from ram	<ul style="list-style-type: none"> • Worn or damaged seals 	<ul style="list-style-type: none"> • Contact service center
Ram will not retract or retracts slower than normal	<ul style="list-style-type: none"> • Malfunctioning coupler, damaged application • Pump reservoir overfilled • Ram damage internally. 	<ul style="list-style-type: none"> • Secure load by other means. Depressurize pump and hoses, remove application and replace coupler. • Secure load by other means. Depressurize pump and hoses, remove application, then drain fluid to proper level • Contact service center
Poor performance	<ul style="list-style-type: none"> • Oil level in pump is low • Air trapped in system 	<ul style="list-style-type: none"> • Ensure proper oil level • Vent the system (refer to figure 3)

Model No. J50200

Item	Part#	Description	Qty.
1	B65073	Wood Chest	1
2	B65775	*Chain Pull Plate (offset attachment)	1
3	B65778	Ram Base	1
4	B65779	Plunger Base	1
5	B65774	*Ram Toe (offset attachment)	1
6	B97518	8' chain w/hook	1
7	B65772	V Head	1
8	B65773	Wedge Head	1
9	B65776	Threaded Coupling	3
10	B65771	Serrated Saddle	2
11	B65770	Connector	1
12	B65760	3" Extension Tube	1
13	B65762	5" Extension Tube	1
14	B65764	10" Extension Tube	1
15	B65766	18" extension tube	1
16	B65768	30" Extension Tube	1
17	HT2005	Ram (refer to page #10)	1
18	CH38F	Female Coupler (3/8" NPTF)	1
21	CS3814M	6' Hydraulic Hose w/ half coupler	1
22	P1000	2-Speed Hand Pump (refer to page #11)	1

*Offset attachments reduce set-up capacity by 50% per attachment. This is in **addition** to the reduction which occurs when adding extension tubes.

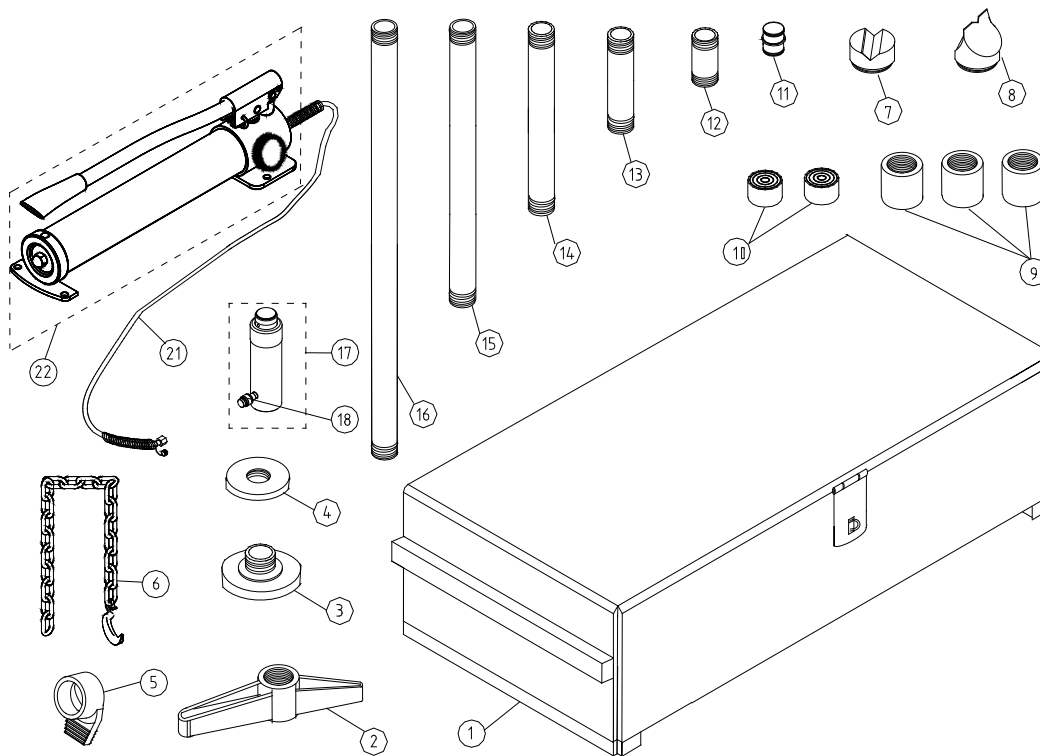
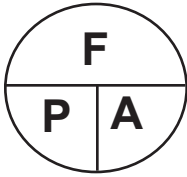

Figure 4 - Replacement Parts Illustration for Model J50200

Load - Pressure Correlation For Model J50200

Always monitor the force applied to workpiece by using a load cell and indicator or you may monitor pressure developed in the ram by using an inline pressure gauge, then calculate the applied force using the formula:



F = P X A
P = F / A
A = F / P

where F = Force/ Load (lb);
 P = Hydraulic working pressure (psi) and;
 A = Ram effective area (in²)

For model J50200, **A** = 5.14 in² ;

Example1

Pressure required to lift 14,000 lb. load:

Pressure = 14,000 lb / 5.14 in² = ~2720 (2,723.735) psi

Load (lb)	Pressure of 20 Ton Ram, where A = 5.14 in ² (psi)
1,000	200
2,000	400
4,000	800
6,000	1200
8,000	1600
10,000	1950
12,000	2350
14,000	2750
16,000	3150
18,000	3500
20,000	3900
22,000	4300
24,000	4700
26,000	5050
28,000	5450
30,000	5850
32,000	6250
34,000	6600
36,000	7000
38,000	7400
40,000	7800





Single Acting Threaded Cylinders Service Parts

MODEL: HT2005

SFA Companies 10939 N. Pomona Ave. Kansas City, MO 64153
 Tel: 888-332-6419 * Fax: 816-448-2142
 E-mail: sales@bvahydraulics.com Website: www.bvahydraulics.com

Note: Not all components of the pump are replacement items, but are illustrated as a convenient reference of location and position in the assembly sequence.

Item	Part No.	Description	Qty
1	H25-6-2305-103	Collar Protective Cap	1
2	H25-5-1103-100	Adapter (threaded)	1
3	*	Dust Seal	1
4	H05-6-1804-100	Threaded Retainer	1
5	649-1-0060-205	Bolt	2
6	*	Special Washer	2
7	N/A	Ram Piston	1
8	H25-5-1204-102	Bearing	1
9	*	Back-up Ring	1
10	*	U-cup	1
11	H25-4-0205-107	Return Spring Assy.	1
12	N/A	Cylinder	1
13	CH38F	Female Coupler	1
14	CDC38	Dust Cap	1
(*)	H25-3-9903-100	Repair Kit	-

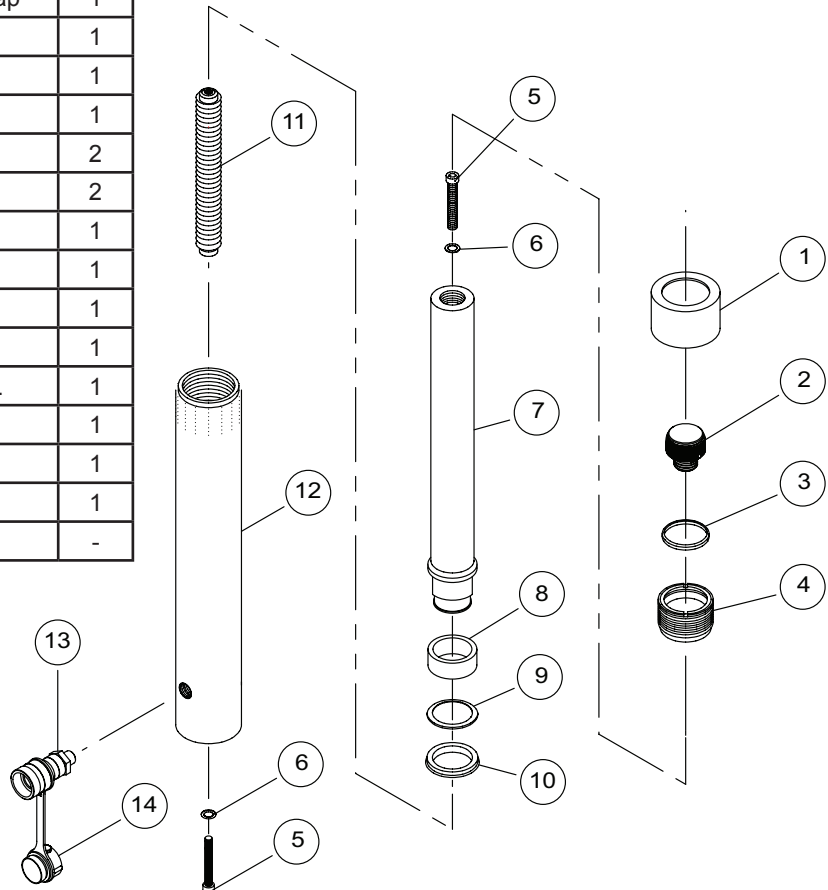

(*) - indicates items included in, and available only as part of Repair Kit
 N/A - part is not available as replacement

Note: To ensure safe and reliable performance, replace worn or damaged parts with BVA Hydraulics Authorized Replacement Parts only.



Hand Pump Service Parts

MODEL: P1000

SFA Companies 10939 N. Pomona Ave. Kansas City, MO 64153
Tel: 888-332-6419 * Fax: 816-448-2142
E-mail: sales@bvahydraulics.com Website: www.bvahydraulics.com

Note: Not all components of the pump are replacement items, but are illustrated as a convenient reference of location and position in the assembly sequence.

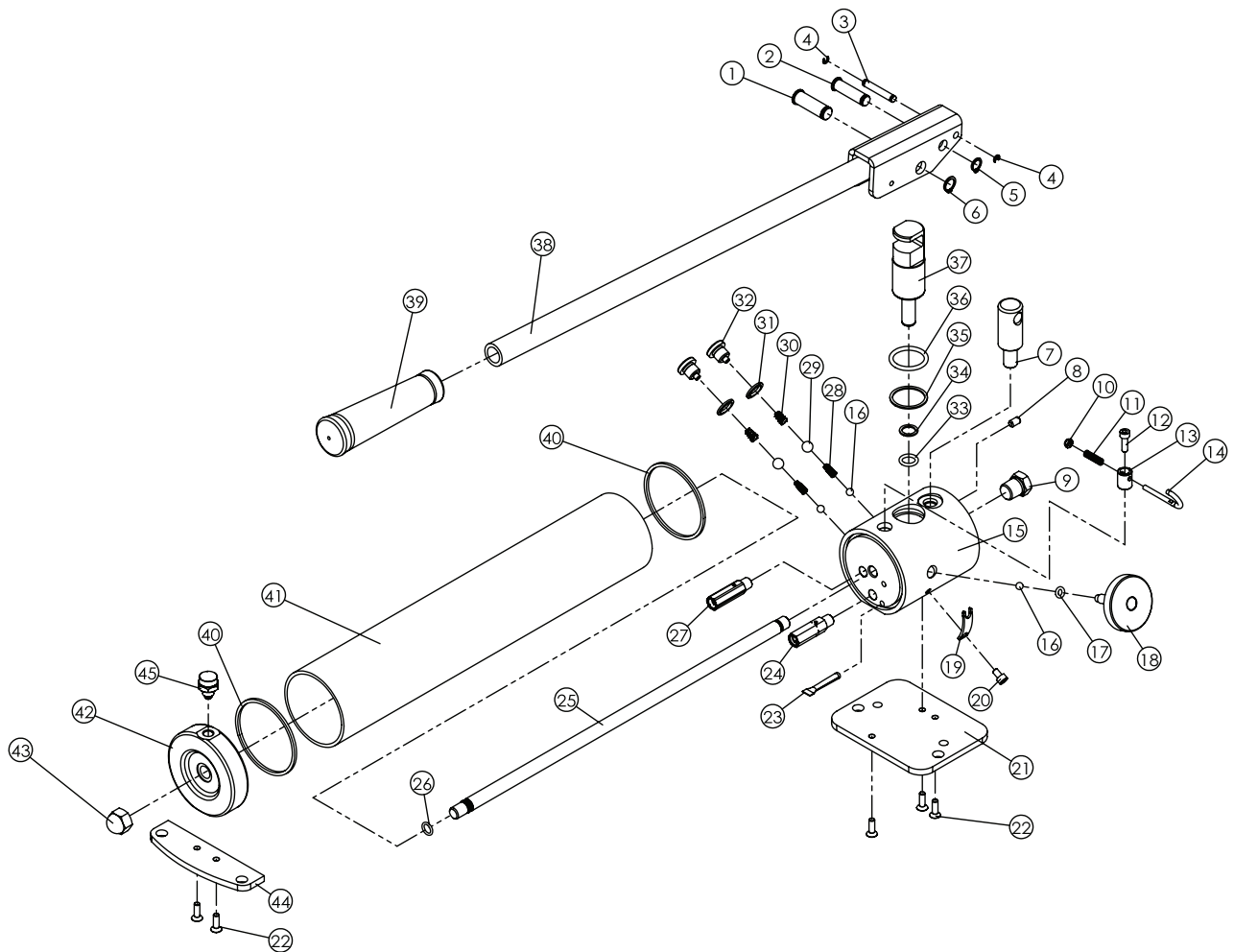



Hand Pump Service Parts

MODEL: P1000

SFA Companies 10939 N. Pomona Ave. Kansas City, MO 64153
 Tel: 888-332-6419 * Fax: 816-448-2142
 E-mail: sales@bvahydraulics.com Website: www.bvahydraulics.com

Note: Not all components of the pump are replacement items, but are illustrated as a convenient reference of location and position in the assembly sequence.

Item	Part Number	Description	Qty
1	H18-6-1317-108	Pin	1
2	H18-6-1318-100	Pin	1
3	H18-5-1318-104	Pin	1
4	677-5-0040-102	E-clip	2
5	667-5-0100-005	C-clip	1
6	667-5-0120-001	C-clip	1
7	H18-6-2114-200	Fixing pillar	1
8	644-1-0060-071	Screw	1
9	D05-6-1001-106	Nut	1
10	661-2-0040-012	Anti-loosen Nut	1
11	512-2-0060-016	Compressing Spring	1
12	649-1-0050-037	Screw	1
13	H18-6-1322-101	Washer base	1
14	H18-6-1321-200	Hook	1
15	N/A	Base	1
16	601-7-0008-009	Steel ball	3
17	*	O-ring	1
18	H18-4-1603-107	Release valve	1
19	H18-6-1308-107	Iron plate	1
20	649-1-0050-028	Screw	1
21	H18-5-1602-101	Base Plate	1
22	651-1-0050-103	Screw	5
23	532-8-0050-024	Filter	1

Item	Part Number	Description	Qty
24	H18-4-1901-105	High pressure Valve Ass.	1
25	H18-5-4401-207	Screw Bar	1
26	*	O-ring	1
27	H18-4-1902-208	Low pressure valve ass.	1
28	552-2-0061-102	Bevel compressing spring	2
29	601-7-0012-000	Steel ball	2
30	552-2-0080-106	Bevel compressing spring	2
31	*	Special Washer	2
32	H18-6-1215-100	Nut	2
33	*	O-ring	1
34	*	Back-up Ring	1
35	*	Back-up Ring	1
36	*	O-ring	1
37	H28-4-4406-108	Piston Ass.	1
38	H18-3-2100-100	Handle	1
39	H18-6-2112-105	Handle Grip	1
40	*	Washer	2
41	H18-6-1911-100	Tube	1
42	H18-6-2122-105	Gable	1
43	671-2-0100-205	Nut	1
44	H18-5-1502-208	Support Plate	1
45	H18-4-1905-103	Air Vent Assy	1
(*)	H18-3-9902-101	Repair Kit	1

(*) - indicates items included in, and available only as part of Repair Kit
 N/A - part is not available as replacement

Note: To ensure safe and reliable performance, replace worn or damaged parts with BVA Hydraulics Authorized Replacement Parts only.