



Hand Pump Instruction Manual

MODEL: ZP601S

SFA Companies 10939 N. Pomona Ave. Kansas City, MO 64153
Tel: 888-332-6419 * Fax: 816-891-6599
E-mail: sales@bvahydraulics.com Website: www.bvahydraulics.com



This is the safety alert symbol. It is used to alert you to potential personal injury hazards. Obey all safety messages that follow this symbol to avoid possible injury or death.

Maximum Operating Pressure 10,000 PSI

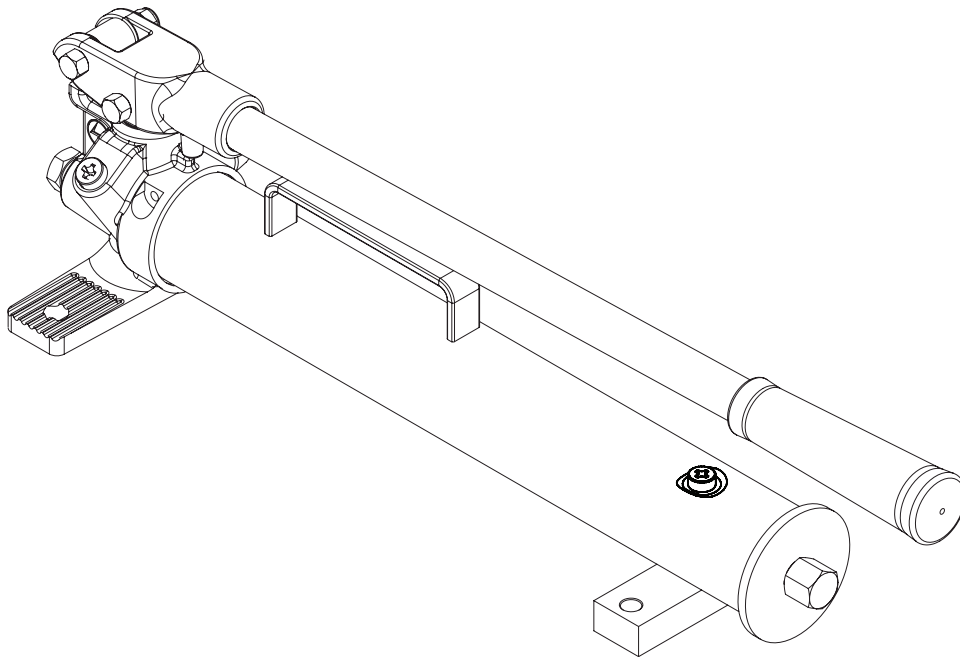

Model ZP601S

SAFETY AND GENERAL INFORMATION

Save these instructions. For your safety, read and understand the information contained within. The owner and operator shall have an understanding of this product and safe operating procedures before attempting to use this product. Instructions and safety information shall be conveyed in operator's native language before use of this product is authorized. Make certain that the operator thoroughly understands the inherent dangers associated with the use and misuse of the product. If any doubt exists as to the safe and proper use of this product as outlined in this factory authorized manual, remove from service immediately.

Inspect before each use. It is recommended that, prior to each use, an inspection be done by qualified personnel and that any missing or damaged parts, decals, warning/safety labels or signs be replaced with factory authorized replacement parts only. Any pump that appears to be damaged in any way, is worn, leaking or operates abnormally shall be removed from service immediately until such time as repairs can be made. Owners and operators of this equipment shall be aware that the use and subsequent repair of this equipment may require special training and knowledge.

PRODUCT DESCRIPTION

BVA Hydraulic Hand Pumps are engineered to meet most industrial standards for Performance and Safety. These lever operated pumps supply compressed hydraulic fluid to compatible applications i.e. rams, presses, spreaders, compactors and crimping machines, anywhere that 10,000 PSI of fluid pressure is needed. Special skill, knowledge and training may be required for a specific task and the product may not be suitable for all the jobs described above. Unsuitable applications would include applications that call for a device to move, level or support persons, animals, hazardous materials, mobile homes/ dwellings in general, mirrors and/or plate glass, and/or to connect/secure hatches, components, etc. between bulkheads. The user must ultimately make the decision regarding suitability of the product for any given task and assume the responsibility of safety for himself and others in the work area.

- ⚠ WARNING:** Always check connections before using. Alteration of these products is strictly prohibited. Use only those adapters and attachments provided and approved by the manufacturer.
- ⚠ WARNING:** To reduce the risk of personal injury and/or property damage, ensure that the rated working pressure of each pressurized attachment be equal to or greater than the rated working pressure developed by the hydraulic pump.
- ⚠ WARNING:** Model ZP601S is operated with a non-vented reservoir. If the reservoir is subjected to high pressure, the casing may rupture. Never attempt to return more oil to the reservoir than it is capable of holding.

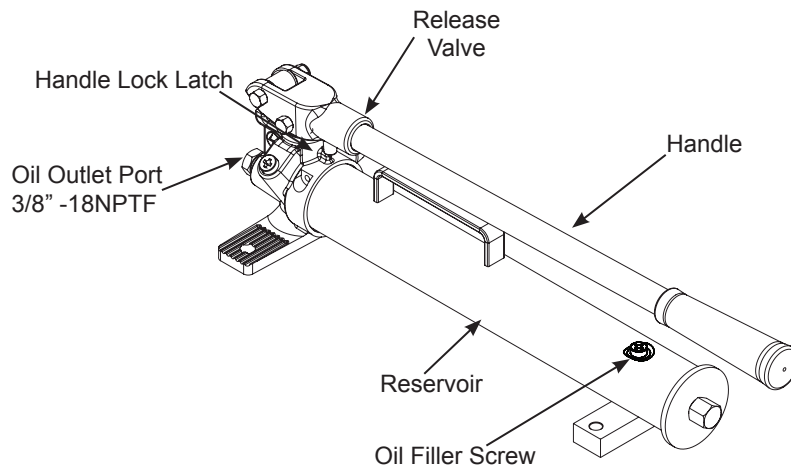

Figure 1 - Model ZP601S Components

SPECIFICATIONS

Model	Pump Type	Usable Oil Capacity (in ³)	Pressure Rating (psi)		Oil Displacement per Stroke (in ³)		Operating Force (lbs)	Piston Stroke (in)	Mounting Plate Holes Distance (in)	Weight (lbs)
			1st Stage	2nd Stage	1st Stage	2nd Stage				
ZP601S	Single-speed	36.61	/	/	/	0.15	99.8	0.75	3.74	16.1

⚠ WARNING



- Study, understand, and follow all instructions provided with and on this device before use.
- All WARNING statements must be carefully observed to help prevent personal injury.
- No alteration shall be made to this device.
- Always wear protective gear when operating hydraulic equipment.
- Keep hydraulic equipment away from flames and heat. Hydraulic fluid can ignite and burn. Do not operate if leaks are detected.
- **Crush Hazard.** Keep hands and feet away from loading area. Avoid pinch points or crush points that can be created by the load, cylinder, or any equipment of system.
- To avoid crushing and related injuries: NEVER work on, under or around a lifted load before it is properly supported by appropriate mechanical means. Never rely on hydraulic pressure alone to support load.

- Do not subject the pump and its components to shock loads.
- Use only approved accessories and approved hydraulic fluid.
- Never attach ANY component not authorized by manufacturer.
- Always ensure that the chosen application is stable to work on and around.
- Do not connect to application which can return more oil to the reservoir than the pump reservoir can hold.
- Do not connect pump to hydraulic system powered by another pump.
- This device is not suitable for use as support device! As the system load is lifted, use blocking and cribbing to guard against a falling load.
- All personnel must be clear before lowering load or depressurizing the system.
- Never try to disassemble a hydraulic cylinder, refer repairs to qualified, authorized personnel.

HYDRAULIC HOSES & FLUID TRANSMISSION LINES

HYDRAULIC PUMPS

- The user must be a qualified operator familiar with the correct operation, maintenance, and use of pumps. Lack of knowledge in any of these areas can lead to personal injury.
- Do not exceed rated capacity of the pump or any equipment in the system.
- Never attempt to lift a load weighing more than the capacity of the cylinder.
- Burst hazard exists if hose or connection pressure exceeds rated pressure.
- Inspect pump, cylinder, hoses and connections before each use to prevent unsafe conditions from developing. Do not use if they are damaged, altered or in poor condition. Do not operate the system with bent or damaged coupler or damaged threads.
- Never hold or stand directly in line with any hydraulic connections while pressurizing.
- Use gauge or other load measuring instrument to verify load.
- Never attempt to disconnect hydraulic connections under pressure. Release all line pressure before disconnecting hoses.

- Avoid short runs of straight line tubing. Straight line runs do not provide for expansion and contraction due to pressure and/or temperature changes.
- Reduce stress in tube lines. Long tubing runs should be supported by brackets or clips. Before operating the pump, tighten all hose connections with proper tools. Do not overtighten. Connections should only be tightened securely and leak-free. Overtightening can cause premature thread failure or high pressure fittings to burst.
- Should a hydraulic hose ever rupture, burst or need to be disconnected, immediately shut off the pump and release all pressure. Never attempt to grasp a leaking pressurized hose with your hands. The force of escaping hydraulic fluid can inflict injury.
- Do not subject the hose to potential hazard such as fire, sharp objects, extreme heat or cold, or heavy impact.
- Do not allow the hose to kink, twist, curl, crush, cut or bend so tightly that the fluid flow within the hose is blocked or reduced. Periodically inspect the hose for wear.
- Do not pull, position or move setup by the hose.
- Hose material and coupler seals must be compatible with hydraulic fluid used. Hoses also must not come in contact with corrosive materials such as battery acid, creosote-impregnated objects and wet paint. Never paint a coupler or hose.
- FAILURE TO HEED THESE WARNINGS MAY RESULT IN PERSONAL INJURY AS WELL AS PROPERTY DAMAGE.

BEFORE USE

1. Before using this product, read the instruction manual completely and familiarize yourself thoroughly with the product, its components and recognize the hazards associated with its use.
2. Verify that the product and the application are compatible. Inspect before each use. Do not use if bent, broken, leaking or damaged components are noted.
3. Replace worn or damaged parts and assemblies with BVA Hydraulics Authorized Replacement Parts only (See Replacement Parts Section). Lubricate as instructed in Maintenance Section.
4. Ensure method of confirming load is accurate and working properly. Have gauge or load cell accuracy verified by qualified personnel on a yearly basis.
5. Pumps should be stored where protected from the elements, abrasive dust, and damage. Pumps can be stored horizontally or vertically.

SETUP

1. Prepare the pump for use:
 - A) For Model ZP601S:
 - Push the handle lock latch to unlock the pump handle (Fig. 2).
2. Carefully remove the oil filler screw from oil outlet port.
3. Connect coupler, fitting or hose of matching threads. Install in-line pressure gauge.

NOTICE: Use an approved, high-grade pipe sealant to seal all hydraulic connections

4. Check for leaks in system and have repaired by qualified personnel as needed. Before repairs are made, depressurize system by opening the release valve counterclockwise, but no more than 2 full turns.

OPERATION

WARNING: ALWAYS monitor pressure, load or position using suitable equipment. Pressure may be monitored by means of an optional manifold and gauge. Load may be monitored by means of a load cell and digital indicator. Correct application position can only be determined by the operator of the equipment.

1. Connect the pump to suitable application.
2. Ensure the oil level is correct and the system fittings and connections are leak free before operating the pump.
3. Pump may be used in horizontal and vertical position as illustrated on Figure 3.
4. Close release valve by turning it clockwise. Finger tight ONLY. Using tools on release valve can damage it and cause the pump to malfunction.
5. Pump handle until desired pressure, load or position is reached.
6. Pressure will maintain until the release valve is opened.
7. To retract application, turn the release valve knob slowly counterclockwise (never more than 2 full turns).

WARNING: NEVER operate pump with release valve closed and disconnected from application. If operated in this condition, the hose and connections become pressurized. This increases burst hazard. Damage may occur to pump and its components.

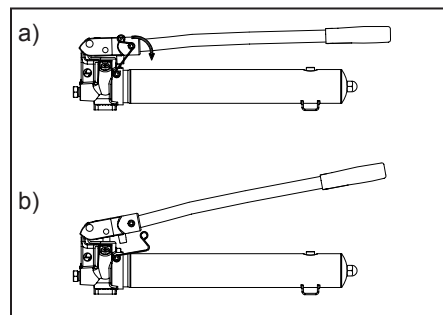

Figure 2 - Push the handle lock latch to unlock the pump handle.

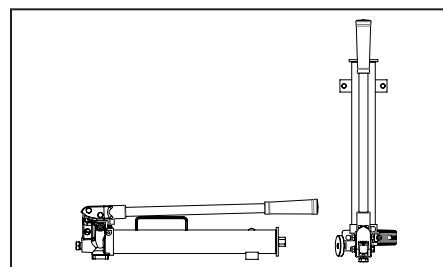

Figure 3 - Horizontal and Vertical Position

MAINTENANCE

1. Inspect hoses and connections daily. Replace damaged components immediately with BVA Hydraulics Replacement Parts only.
2. Tighten connections as needed. Use pipe thread sealing compound when servicing connections.
3. Use only good quality hydraulic fluid. We recommend using premium hydraulic fluid. **Never** use brake fluid, transmission fluid, turbine oil, motor oil, alcohol, glycerin etc. Use of other than good quality hydraulic oil will void warranty and damage the pump, hose, and application.

Adding Hydraulic Fluid

1. Depressurize and disconnect hydraulic hose from application.
2. With pump in its upright, horizontal position, remove oil filler plug/screw located on top of the reservoir.
3. Use a small funnel to fill reservoir to within 1/4" (6 mm) of the opening.
4. Wipe up any spilled fluid and reinstall the oil filler plug/screw.

Changing Hydraulic Fluid

For best results, change fluid once a year.

1. With pump in its upright, horizontal position, remove oil filler plug/screw located on top of the reservoir, then pour used fluid into a sealable container.
2. Dispose of fluid in accordance with local regulations.
3. Fill with a good quality hydraulic jack oil as recommended above. Reinstall vented oil filler plug/screw.

Lubrication

Use a light machine oil to lubricate pivot points, hinges etc.

Storage

1. When not in use, depressurize and disconnect hoses from application.
2. Wipe clean, thoroughly
3. Store in clean, dry environment. Avoid temperature extremes. Lock handle into position using the spring loaded locking pin mechanism.
4. Shield pump with a protective cover.

TROUBLESHOOTING GUIDE

The following information is intended as an aid in determining if problem exists. Pumps should be repaired only by authorized BVA Service Center. For repair service, contact service center in your area.

Symptom	Possible Causes	Corrective Action
Erratic application action	<ul style="list-style-type: none"> • Air in the system. • External leak. • Internal hydraulic leak. 	<ul style="list-style-type: none"> • Vent the system. • Tighten all connections. • Contact service center.
Application does not extend, move or respond to pressurized fluid	<ul style="list-style-type: none"> • Overload condition. • Release valve not closed. • Loose couplers/connections. • Faulty couplers/connections. • Pump malfunction. 	<ul style="list-style-type: none"> • Remedy overload condition. • Ensure release valve closed. • Tighten couplers/connections. • Replace couplers/connections. • Contact service center.
Application responds to pressurized fluid, but system does not maintain pressure	<ul style="list-style-type: none"> • Overload condition. • Release valve not closed. • Pump or valve malfunction. • Application/connection leaking. 	<ul style="list-style-type: none"> • Remedy overload condition. • Ensure release valve closed. • Contact Service Center. • Replace application/connection.
Application responds slower than normal	<ul style="list-style-type: none"> • Loose connection or coupler. • Restricted hydraulic line or fitting. • Application/connection leaking. 	<ul style="list-style-type: none"> • Tighten connection or coupler. • Clean and replace if damaged. • Replace application/connection.
Application does not return fluid to pump (i.e. cylinder will not retract)	<ul style="list-style-type: none"> • Malfunctioning coupler, damaged application. • Reservoir overfilled 	<ul style="list-style-type: none"> • Secure load by other means. Open release valve, depressurize pump and hose, remove coupler and/or application, then renew or replace. • Secure load by other means. Open release valve, depressurize pump and hose, remove application, then drain fluid to proper level.
Poor performance	<ul style="list-style-type: none"> • Fluid level in pump is low. 	<ul style="list-style-type: none"> • Ensure proper fluid level.



Hand Pump Service Parts

MODEL: ZP601S

SFA Companies 10939 N. Pomona Ave. Kansas City, MO 64153
Tel: 888-332-6419 * Fax: 816-891-6599
E-mail: sales@bvahydraulics.com Website: www.bvahydraulics.com

Note: Not all components of the pump are replacement items, but are illustrated as a convenient reference of location and position in the assembly sequence.

Parts Illustration

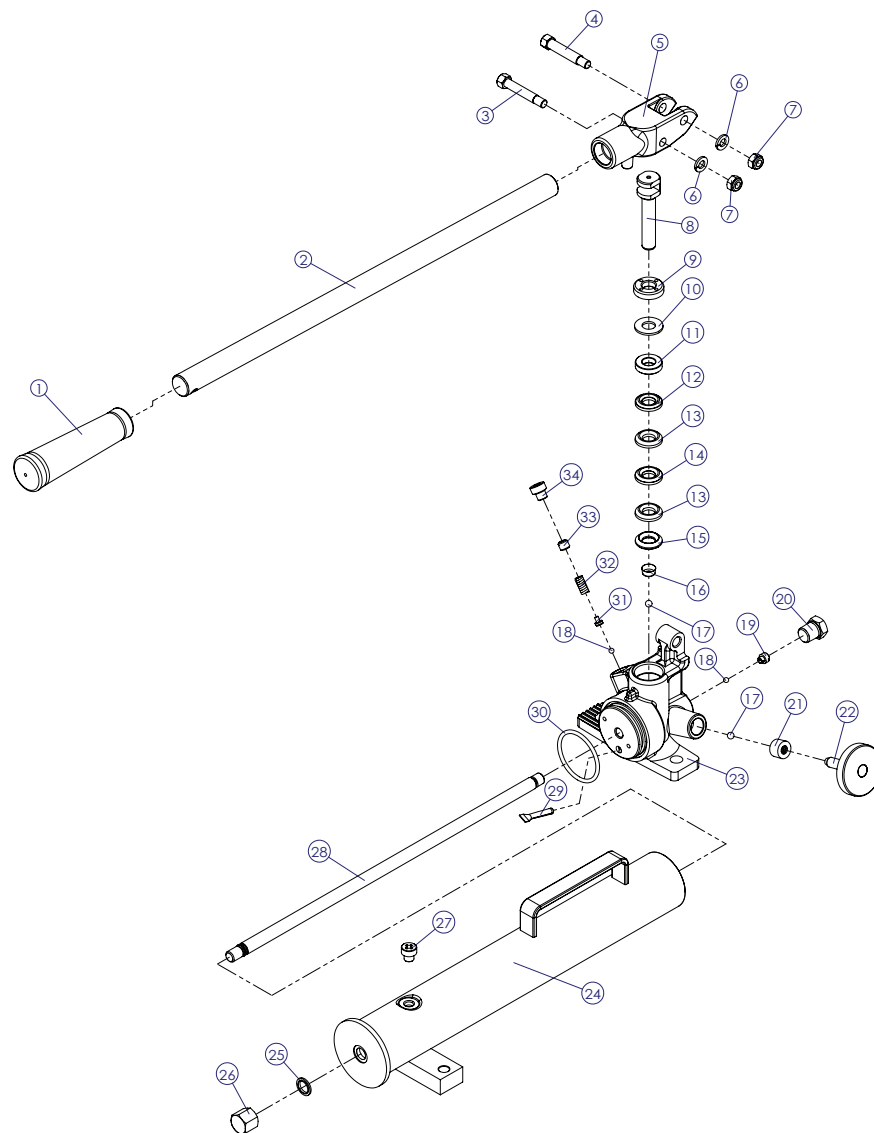

Note: To ensure safe and reliable performance, replace worn or damaged parts with BVA Hydraulics Authorized Replacement Parts only.

Parts List Model ZP601S

Item	Part Number	Description	Qty
1	H18-6-2112-105	Handle Grip	1
2	H54-6-2139-109	Handle	1
3	H54-6-2138-107	Pin	1
4	H54-6-2137-105	Pin	1
5	H54-6-2136-103	Handle Socket	1
6	605-3-0080-102	Spring Washer	2
7	661-2-0080-014	Nut	2
8	430-6-1601-209	Piston	1
9	428-6-1104-203	Screw adjustment	1
10	513-3-0270-010	Washer	1
11	428-6-1103-100	Upper seal base	1
12	*	V-oil seal	1
13	*	V-oil seal	2
14	*	V-oil seal	1
15	428-6-1102-209	Lower seal base	1
16	522-8-0127-016	Filter	1
17	601-7-0008-009	Steel Ball	2
18	601-7-0006-005	Steel Ball	2
19	426-6-1105-201	Bolt	1
20	D05-6-1001-106	Oil Plug	1
21	*	Valve seal	1
22	H54-4-2105-100	Release valve	1
23	N/A	Base	1
24	H54-3-2134-202	Reservoir	1
25	*	Bonded seal	1
26	H28-6-4404-106	Nut	1
27	324-4-1900-309	Oil Filler Screw	1
28	H18-5-4401-207	Screw Bar	1
29	532-8-0050-024	Filter	1
30	*	O-ring	1
31	501-9-0085-202	Steel Ball Block	1
32	516-2-0080-010	Compressing Spring	1
33	426-6-1201-106	Adjustment Screw	1
34	324-4-1900-309	Screw	1
(*)	H54-3-9903-107	Repair Kit	

(*) - indicates items included in, and available only as part of Seal Kit
 N/A - part is not available as replacement

LIMITED LIFETIME WARRANTY

BVA Hydraulics®, represented in the United States by SFA Companies ["SFA"] warrants this product to be free from defects in material and workmanship for the life of the product as long as the original purchaser owns the product. The warranty is non-transferable and is subject to the terms, exclusions, and limitations described below:

- Damaged components, including but not limited to bent rams, dented or crushed cylinder walls, broken welds or couplers as well as worn out seals, o-rings and springs are the result of misuse and not covered by warranty and BVA Hydraulics will not provide any warranty credit for such damaged components.
- This warranty does not cover ordinary wear and tear, overloading, alterations (including repairs or attempted repairs not performed by BVA Hydraulics or one of its authorized personnel), improper fluid use, or use of the product in any manner for which the product was not intended or the use of which is not in accordance with the instructions or warnings provided with the product.
- In the unlikely event that a BVA Hydraulics product fails due to material defect in workmanship, you may contact SFA for disposition. In such cases, the customer's sole and exclusive remedy for any breach or alleged breach of warranty is limited to the repair or replacement of the defective product.
- Under no circumstances is BVA Hydraulics liable for any consequential or incidental damage or loss whatsoever.
- THIS WARRANTY IS LIMITED TO NEW PRODUCTS SOLD THROUGH AUTHORIZED DISTRIBUTORS AND OTHER CHANNELS DESIGNATED BY BVA HYDRAULICS. NO AGENT, EMPLOYEE OR OTHER REPRESENTATIVE OF BVA HYDRAULICS IS AUTHORIZED TO MODIFY THIS WARRANTY.
- THE FOREGOING IS EXCLUSIVE AND IS IN LIEU OF ALL OTHER EXPRESS AND IMPLIED WARRANTIES, INCLUDING BUT NOT LIMITED TO THE IMPLIED WARRANTIES OF MERCHANTABILITY AND FOR A FITNESS FOR A PARTICULAR PURPOSE.
- Components not manufactured by BVA Hydraulics including certain motor systems, gasoline engines, and others are not covered by this warranty and instead are covered by the manufacturer's separate manufacturer's warranty provided in the package.
- BVA Hydraulics' liability in all cases is limited to, and will not exceed the purchase price paid for the product.

