



BVA[®]

HYDRAULICS



Remote Manual Directional Valves

Features:

- Designed and manufactured for safe operation to 10,000 psi
- Advance/Hold/Retract operation for use with single-acting or double-acting cylinders
- 4.5 gal/min. maximum flow capacity



PR33

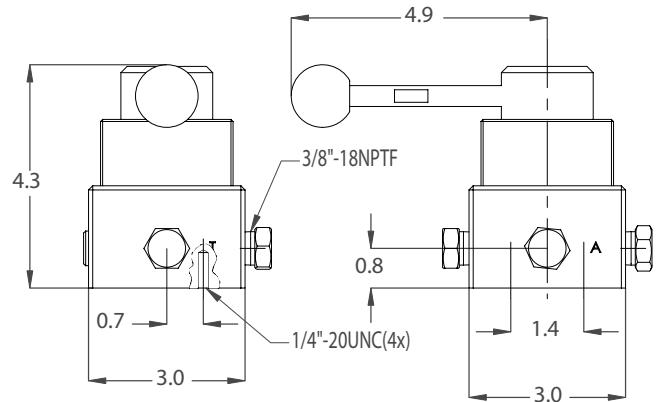

PR33



PR43C

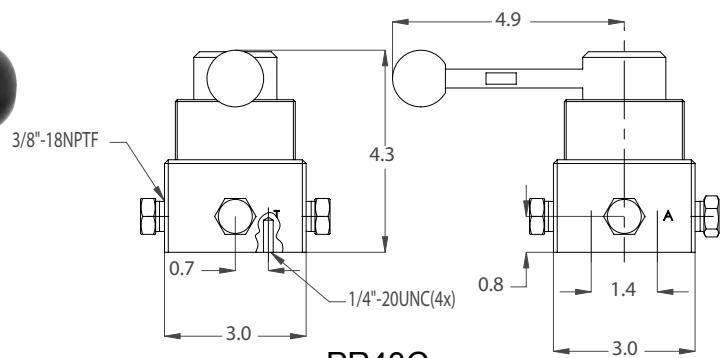

PR43C

Valve Type	Model	Hydraulic Symbol	Schematic Flowpath		
			Advance	Hold	Retract
3-way, 3 position Tandem Center	PR33				
4-way, 3 Position Closed Center	PR43C				

BUILT TO LAST