

ROTARY AIR PUMPS

- Two speed operation for fast cylinder advance and improved productivity
- Models available with auto return valve
- Internal relief valves for overload protection
- Ideal for application in areas where combustible material or gases are present

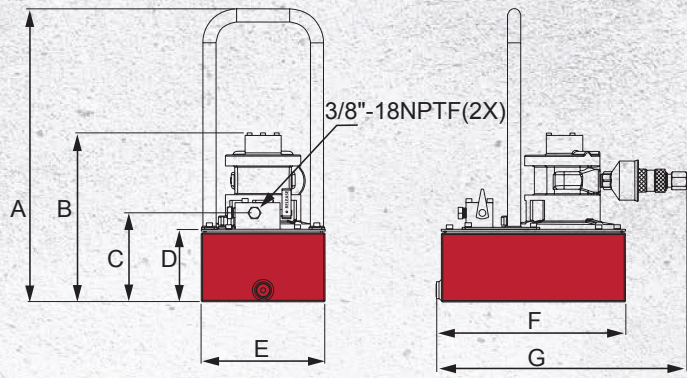

PARD1703

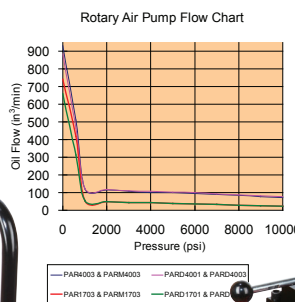
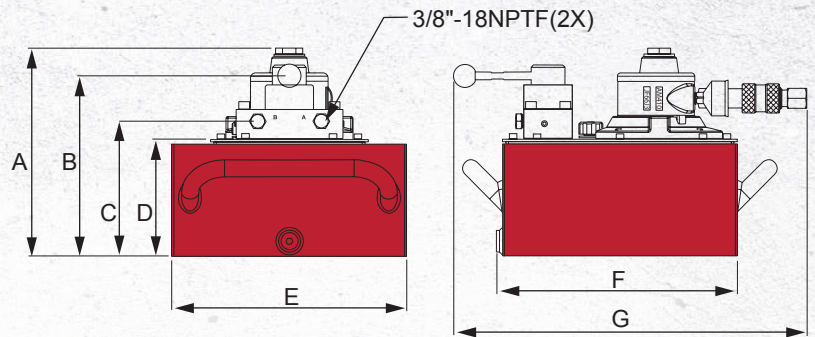

PAR4003



PARD1703



PAR4003

Used with Cylinder	Motor Size (hp)	Usable Oil Capacity (gal)	Model Number	Pressure Rating (psi)	Pressure Rating		Oil Output Flow Rate		Valve Type	Valve Function	Air pressure range (psi)
					1st Stage (psi)	2nd Stage (psi)	1st Stage (in³/min)	2nd Stage (in³/min)			
Single Acting	1.7	1	PARD1701	10,000	700	10,000	313	22	Dump	Advance/Return	60 ~ 80
	1.7	3	PARD1703	10,000	700	10,000	313	22	Dump	Advance/Return	60 ~ 80
	1.7	3	PAR1703	10,000	700	10,000	417	22	Manual PW3	Advance/Hold/Return	60 ~ 80
	4	1	PARD4001	10,000	700	10,000	465	70	Dump	Advance/Return	60 ~ 100
	4	3	PARD4003	10,000	700	10,000	465	70	Dump	Advance/Return	60 ~ 100
	4	3	PAR4003	10,000	700	10,000	512	70	Manual PW3	Advance/Hold/Return	60 ~ 100
Double Acting	1.7	3	PARM1703	10,000	700	10,000	417	22	Manual PW4	Advance/Hold/Return	60 ~ 80
	4	3	PARM4003	10,000	700	10,000	512	70	Manual PW4	Advance/Hold/Return	60 ~ 100

Model Number	Air Consumption (cfm)	Sound Level (dBA)	Dimensions (in)							Weight (lbs)
			A	B	C	D	E	F	G	
PARD1701	44	93	19.10	9.39	5.79	4.72	8.07	12.34	15.90	42
PARD1703	44	93	-	11.95	8.35	7.28	12.01	12.34	17.96	54
PAR1703	44	93	11.94	10.53	8.21	7.28	12.01	12.34	18.08	55
PARD4001	95	100	19.10	11.00	5.79	4.72	8.07	12.34	16.34	54
PARD4003	95	100	-	13.56	8.35	7.28	12.01	12.34	18.4	66
PAR4003	95	100	13.55	10.53	8.21	7.28	12.01	12.34	18.52	67
PARM1703	44	93	11.94	10.53	8.21	7.28	12.01	12.34	18.08	55
PARM4003	95	100	13.55	10.53	8.21	7.28	12.1	12.34	18.52	67